

**GigaDevice Semiconductor Inc.**

**GD32350G-START  
User Manual**

## Table of Contents

### 目录

<b>Table of Contents .....</b>	<b>1</b>
<b>List of Figures.....</b>	<b>3</b>
<b>List of Tables .....</b>	<b>4</b>
<b>1. Summary.....</b>	<b>5</b>
<b>2. Function Pin Assign.....</b>	<b>5</b>
<b>3. Getting started.....</b>	<b>5</b>
<b>4. Hardware layout overview.....</b>	<b>6</b>
<b>4.1. Power supply.....</b>	<b>6</b>
<b>4.2. Boot option.....</b>	<b>6</b>
<b>4.3. LED.....</b>	<b>6</b>
<b>4.4. KEY.....</b>	<b>7</b>
<b>4.5. USBFS.....</b>	<b>7</b>
<b>4.6. GD-Link.....</b>	<b>8</b>
<b>4.7. Extension.....</b>	<b>8</b>
<b>4.8. MCU.....</b>	<b>9</b>
<b>5. Routine use guide.....</b>	<b>9</b>
<b>5.1. GPIO_Runing_Led.....</b>	<b>9</b>
5.1.1. DEMO Purpose.....	9
5.1.2. DEMO Running Result.....	9
<b>5.2. GPIO_KeyBoard_Polling_mode.....</b>	<b>9</b>
5.2.1. DEMO Purpose.....	9
5.2.2. DEMO Running Result.....	10
<b>5.3. GPIO_KeyBoard_Interrupt_mode.....</b>	<b>10</b>
5.3.1. DEMO Purpose.....	10
5.3.2. DEMO Running Result.....	10
<b>5.4. USB_FS.....</b>	<b>10</b>
5.4.1. USBD_CDC_ACM.....	10
5.4.2. USBD_Keyboard.....	11
5.4.3. USBH_MSC_Host.....	12

---

<b>6. Revision history.....</b>	<b>12</b>
---------------------------------	-----------

## List of Figures

<i>Figure 4-1 Schematic diagram of power supply</i> .....	6
<i>Figure 4-2 Schematic diagram of boot option</i> .....	6
<i>Figure 4-3 Schematic diagram of LED function</i> .....	6
<i>Figure 4-4 Schematic diagram of Key function</i> .....	7
<i>Figure 4-5 Schematic diagram of USBFS function</i> .....	7
<i>Figure 4-6 Schematic diagram of GD-Link function</i> .....	8
<i>Figure 4-7 Schematic diagram of Extension Pin</i> .....	8
<i>Figure 4-8 Schematic diagram of MCU Pin</i> .....	9

## List of Tables

<b>Table 2-1 Pin assignment</b> .....	5
<b>Table 4-1 Boot configuration</b> .....	6
<b>Table 6-1 Revision history</b> .....	12

## 1. Summary

GD32350G-START board uses GD32F350G8 as the main controller. As a complete development platform of GD32F3x0 powered by ARM® Cortex™-M4 core, the board supports full range of peripherals. It uses mini-USB interface or AC/DC adapter to supply 5V power. SWD, Reset, Boot, User button key, LED and Extension Pin are also included. This document details its hardware schematic and the relevant applications.

## 2. Function Pin Assign

Table 2-1 Pin assignment

Function	Pin	Description
LED	PA1	LED1
KEY	PA0	K1-User Key
RESET		K2-Reset
USB	PA11	USBDM
	PA12	USBDP
	PA8	USBCTR
	PA9	USBVBUS

## 3. Getting started

The START Board uses mini-USB connector or AC/DC adapter to get power, the hardware system power is +3.3V. A mini-USB cable are necessary to down programs. Select the correct boot mode and then power on, the LED3 will turn on, which indicates the power supply is ready.

## 4. Hardware layout overview

### 4.1. Power supply

Figure 4-1 Schematic diagram of power supply

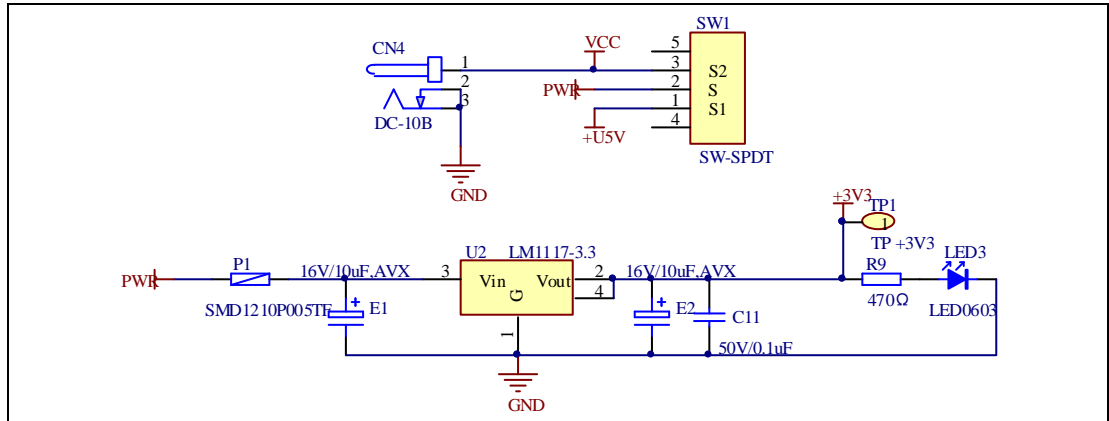

### 4.2. Boot option

Figure 4-2 Schematic diagram of boot option

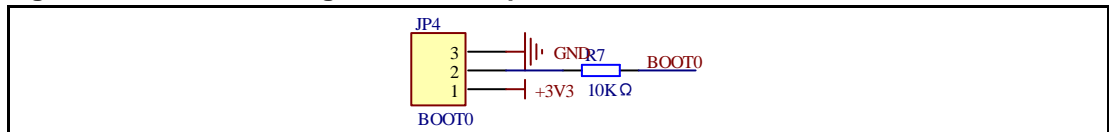
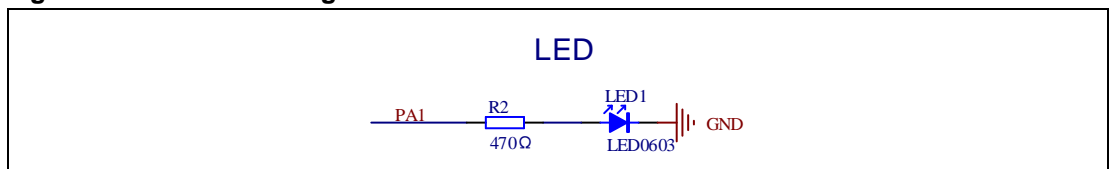

Table 4-1 Boot configuration

BOOT1	BOOT0	Boot Mode
Default	2-3	User memory
	1-2	System memory
Changed by ISP	1-2	SRAM memory

### 4.3. LED

Figure 4-3 Schematic diagram of LED function



#### 4.4. KEY

Figure 4-4 Schematic diagram of Key function

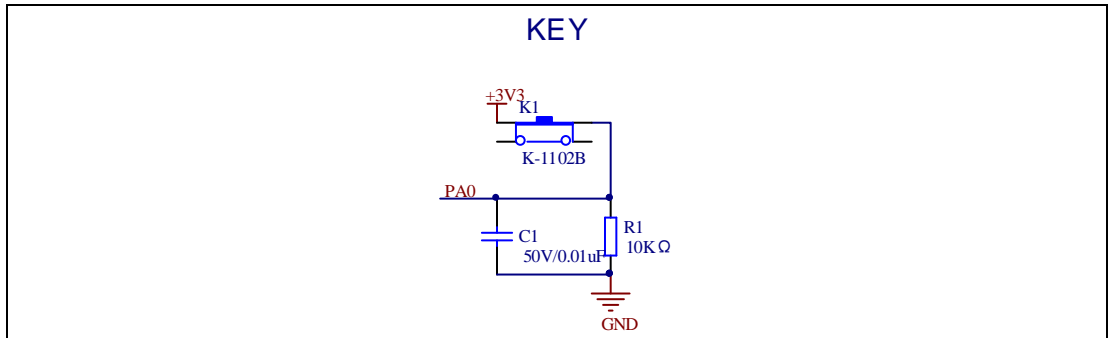

#### 4.5. USBFS

Figure 4-5 Schematic diagram of USBFS function

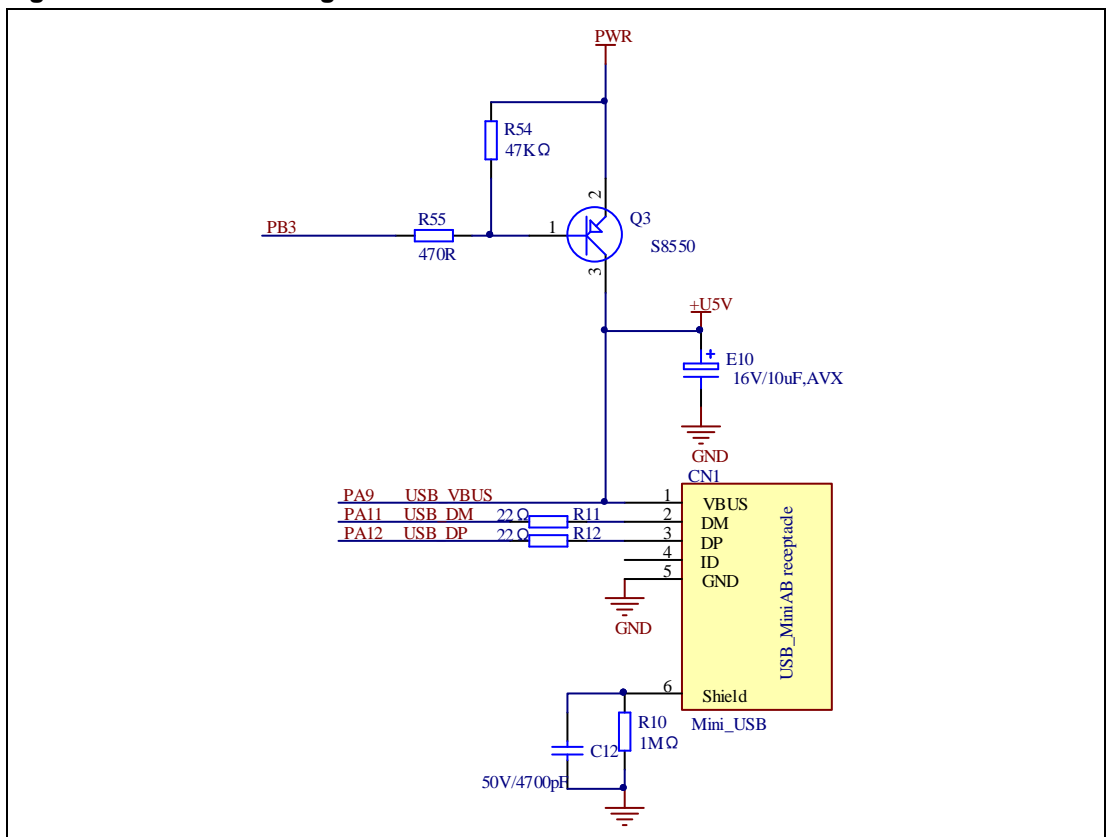



## 4.6. GD-Link

Figure 4-6 Schematic diagram of GD-Link function

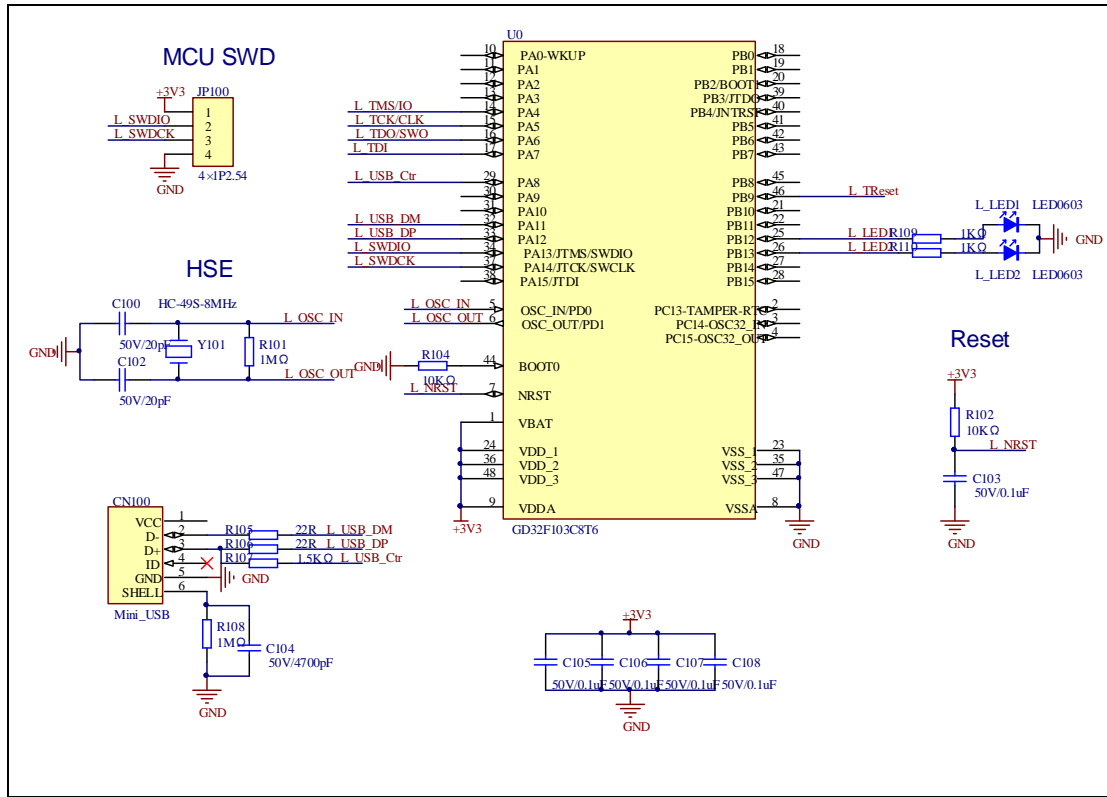

## 4.7. Extension

Figure 4-7 Schematic diagram of Extension Pin

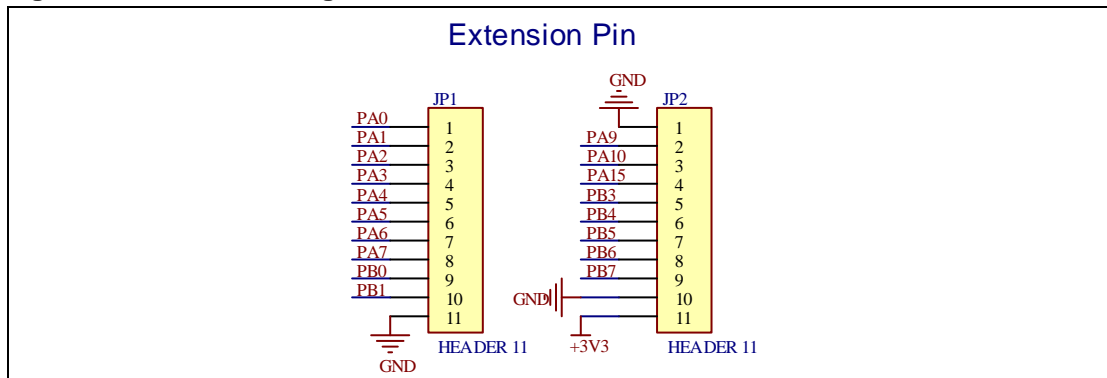

## 4.8. MCU

Figure 4-8 Schematic diagram of MCU Pin

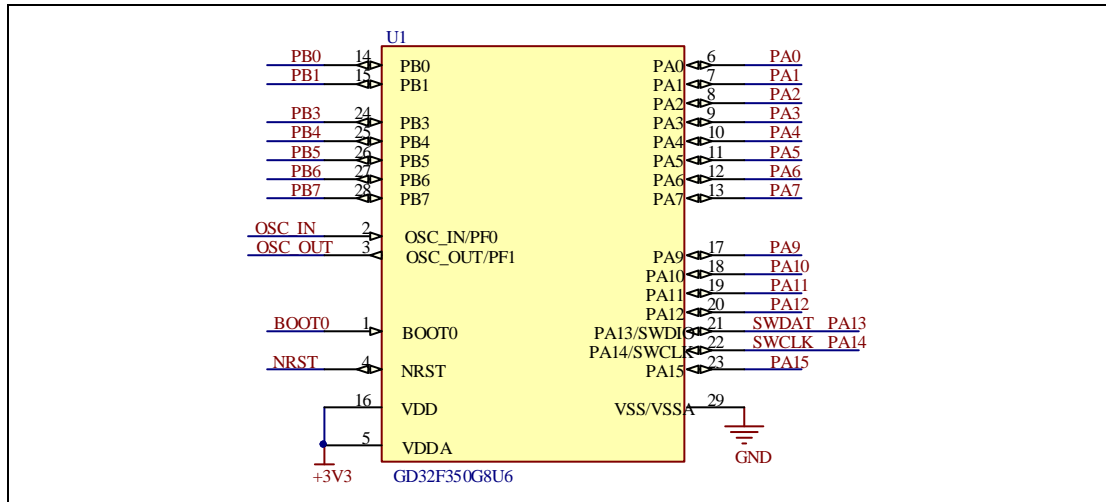

## 5. Routine use guide

### 5.1. GPIO\_Runing\_Led

#### 5.1.1. DEMO Purpose

This Demo includes the following functions of GD32 MCU:

- Learn to use GPIO for controlling the LED
- Learn to use SysTick to generate 1ms delay

GD32350G-START board has one LED. The LED1 is controlled by GPIO. This demo will show how to light the LED.

#### 5.1.2. DEMO Running Result

Download the program <01\_GPIO\_Runing\_Led> to the board, the state of LED1 is toggled every 1s.

### 5.2. GPIO\_KeyBoard\_Polling\_mode

#### 5.2.1. DEMO Purpose

This Demo includes the following functions of GD32 MCU:

- Learn to use GPIO control the LED and the KEY
- Learn to use SysTick to generate 1ms delay

GD32350G-START board has two keys and one LED. The two keys are Reset key and User key. The LED1 is controlled by GPIO.

This demo will show how to use the User key to control the LED1. When press down the User Key, it will check the input value of the IO port. If the value is 1, wait for 50ms. Then check the input value of the IO port again. If the value is still 1, indicates that the button is pressed down successfully, and light the four LED1.

### 5.2.2. DEMO Running Result

Download the program <02\_GPIO\_KeyBoard\_Polling\_mode> to the board, first of all, all the LEDs will be flashed once for test. Then press down the User Key, LED1 will be turned on. Press down the User Key again, LED1 will be turned off.

## 5.3. GPIO\_KeyBoard\_Interrupt\_mode

### 5.3.1. DEMO Purpose

This Demo includes the following functions of GD32 MCU:

- Learn to use GPIO to control the LED and the KEY
- Learn to use EXTI to generate external interrupt

GD32350G-START board has two keys and one LED. The two keys are Reset key and User key. The LED1 is controlled by GPIO.

This demo will show how to use EXTI interrupt line to control the LED1. When press down the User Key, it will produce an interrupt. In the interrupt service function, the demo will toggle LED1.

### 5.3.2. DEMO Running Result

Download the program <03\_GPIO\_KeyBoard\_Interrupt\_mode> to the board, first of all, all the LEDs will be flashed once for test. Then press down the User Key, LED1 will be turned on. Press down the User Key again, LED1 will be turned off.

## 5.4. USB\_FS

### 5.4.1. USBD\_CDC\_ACM

#### DEMO Purpose

This demo includes the following functions of GD32 MCU:

- Learn how to use the USBFS peripheral
- Learn how to implement USB CDC device

Start board has one USBFS interface. In this demo, the Start board is enumerated as an USB virtual COM port, which was shown in device manager of PC as below. This demo makes the USB device look like a serial port, and loops back the contents of a text file over USB port. To run the demo, input a message using the PC's keyboard. Any data that shows in HyperTerminal is received from the device.

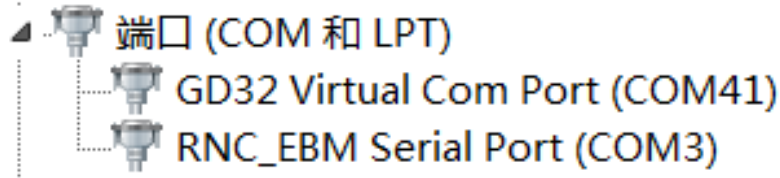

### DEMO Running Result

Download the program <04\_USBFS\Device\CDC\_ACM> to the Start board and run. When you input message through computer keyboard, the HyperTerminal will receive and shown the message. For example, when you input "GigaDevice MCU", the HyperTerminal will get and show it as below.



### 5.4.2. USBD\_Keyboard

#### DEMO Purpose

This demo includes the following functions of GD32 MCU:

- Learn how to use the USBFS peripheral mode
- Learn how to implement USB HID(human interface) device

Start board has two keys and one USB\_FS interface. The two keys are Reset key and User key. In this demo, the Start board is enumerated as an USB Keyboard, which uses the native PC Host HID driver, as shown below. The USB Keyboard uses one key (user key) to output one characters ('c').



### DEMO Running Result

Download the program <04\_USBFS\Device\HID\_Keyboard> to the Start board and run. If you press the User key, will output 'c'.

### 5.4.3. USBH\_MSC\_Host

#### DEMO Purpose

This demo includes the following functions of GD32 MCU:

- Learn to use the USBFS as a MSC host
- Learn the operation between the MSC host and the Udisk

Start board integrates the USBFS module, and the module can be used as USBFS device, a USBFS host or OTG device. This demo mainly shows how to use the USBFS as a USB MSC host to communicate with external Udisk.

#### DEMO Running Result

Insert the OTG cable to the USB port, download the program <04\_USBFS\Host\MSC> to the Start board and run.

If an Udisk has been attached, firstly, a press the user key, then this demo will write file to the Udisk. Then, if the MSC host demo is end, the LED1 will be on.

## 6. Revision history

Table 5-1 Revision history

Revision No.	Description	Date
1.0	Initial Release	Jun.28, 2017